

WELD GUN CYLINDER HOLDERS

- * Designed for air and hydraulic guns and cylinders on resistance spot welding equipment.
- * **Individual supply of water and current** to each holder for better weld quality.
- * **Silver plated** barrel and clamp for higher conductivity and corrosion resistance.
- * Available for **4 RW, 5 RW, 6 RW,** and **7 RW** taper electrodes.
- * When ordering, specify assembly size as shown below.
- * **To complete your set-up,** order hose barb, adapters, stationary water tubes and sliding tubes to suit your specific requirements.
- * **Replacement parts may be ordered individually**

T-101

Barrel and Clamp Assembly
For 4 RW and 5 RW Electrodes

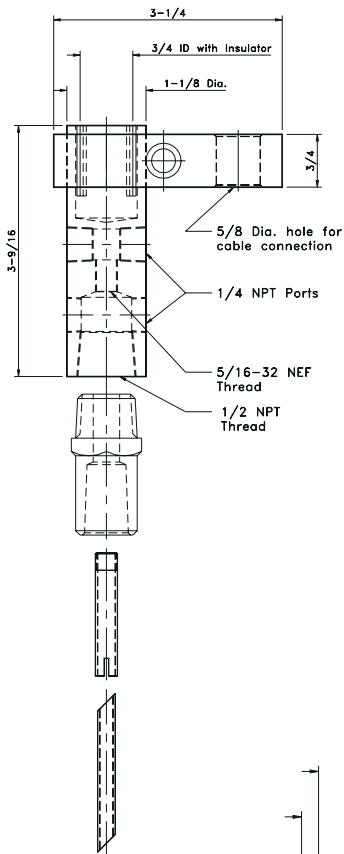

T-102

Barrel and Clamp Assembly
For 6 RW or 7 RW Electrodes

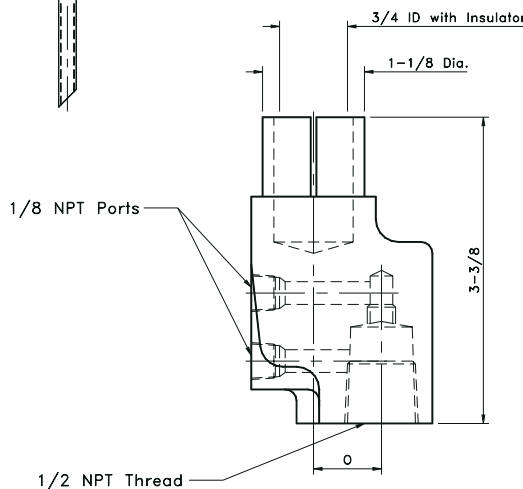
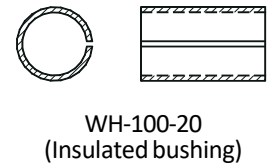
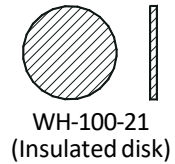
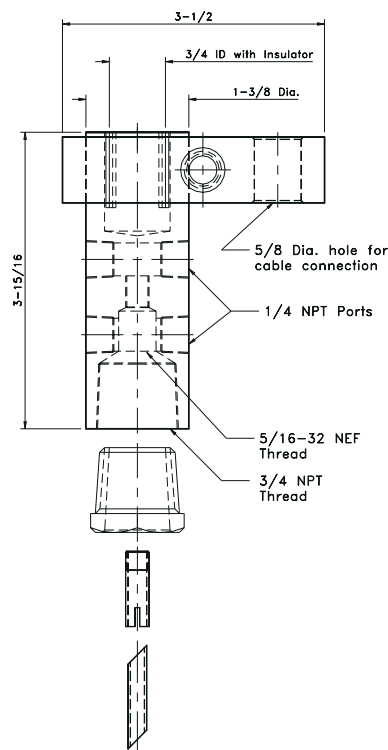

OFFSET HOLDERS

Part No.	Offset
T-101-.50	1/2"
T-101-.75	3/4"
T-101-1.0	1"

OPTIONS

- * Additional offsets
- * #6 & #7 RW Tapers
- * 3/4 NPT water connections