

TIP DRESSING BLADES & CHUCKS

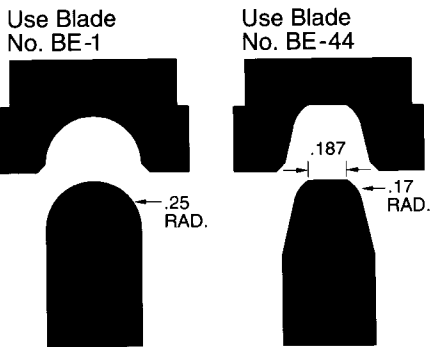

Table Dresser

This off-line table dresser is perfect for high production redressing of cap tips. This machine will accommodate both male and female caps (with available tooling)

PART # DT-1

For No. 4RW Electrodes Use Chuck No. C-1; Nut N-1, Ring No. R-2



For No. 5RW Electrodes Use Chuck No. C-1; Nut N-1, Ring No. R-1

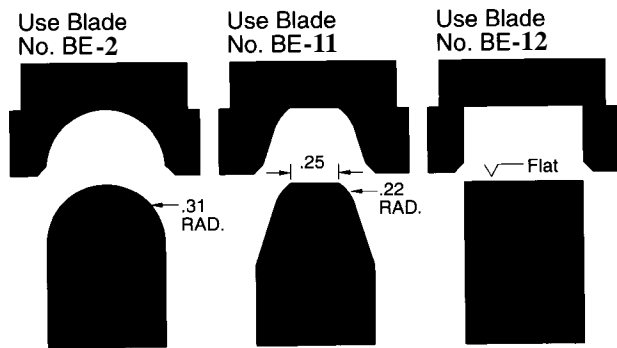

For No. 6RW Electrodes Use Chuck No. C-2; Nut N-2

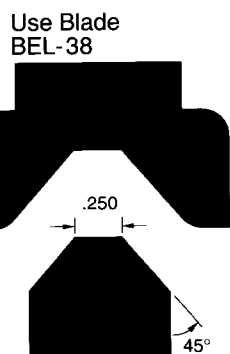
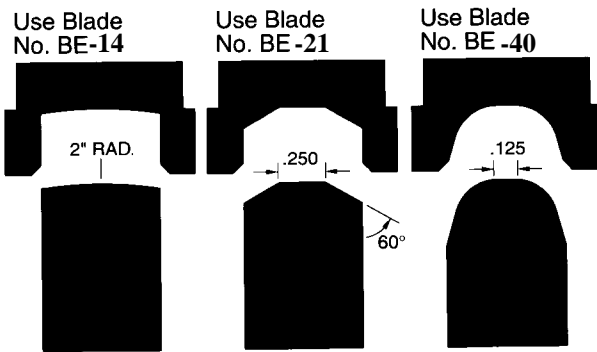
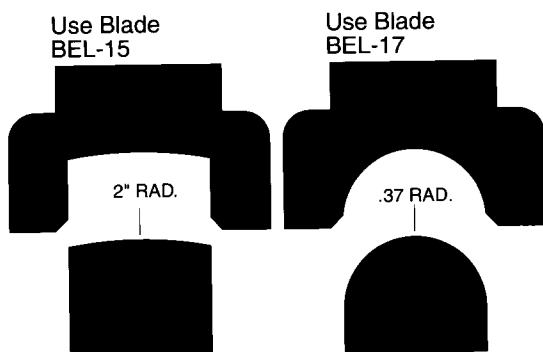

For No. 7RW Electrodes Use Chuck No. C-2; Nut N-3

