

TIP DRESSING BLADES & CHUCKS



FLUSH TYPE STRAIGHT

For No. 4RW Electrodes Use
chuck No. C-6 for all.



FLUSH TYPE TAPERED

For No. 4RW Electrodes
Use chuck No. C-3 for all.

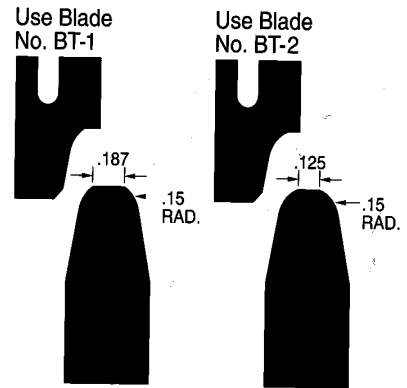
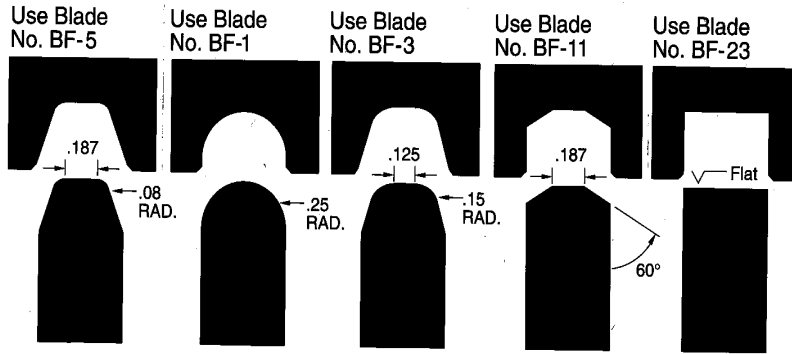

**For No. 5RW Pointed Electrodes
Use chuck No. C-4 for all**

**For No. 5RW Electrodes
Use chuck No. C-5 for all**

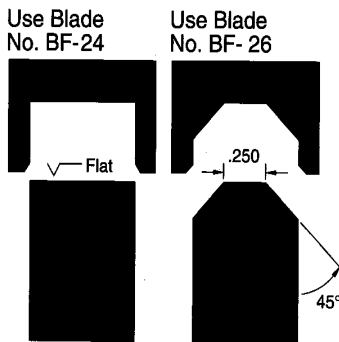
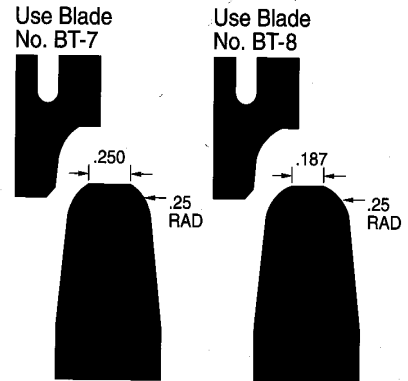
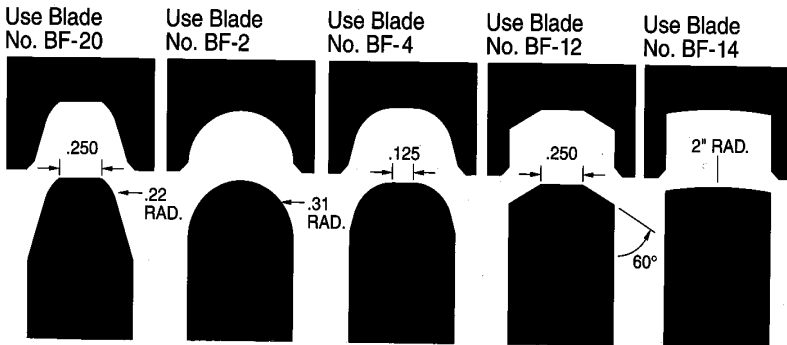

**Solid Style Cutters, 1 Piece
For #4 & #5RW Electrodes**



**Flush Style
Solid Cutter**



**Extended
Solid Cutter**

**Lathe or Drill Press
Adaptor**

