

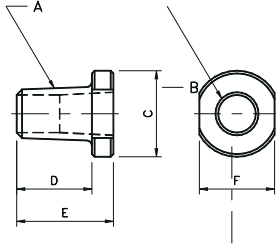

Email: [Tipaloy@Tipaloy.com](mailto:Tipaloy@Tipaloy.com) Phone: 313-875-5145 Web: [www.Tipaloy.com](http://www.Tipaloy.com)

## TIP ADAPTERS



EXAMPLE OF PART CODING:	
AT	= TAPER
H	= HEX STOCK
R	= ROUND STOCK
2	= CLASS 2 COPPER
4	= # 4 RW FEMALE TAPER
5	= # 5 RW MALE TAPER
8	= LENGTH IN 1/8" INCREMENTS

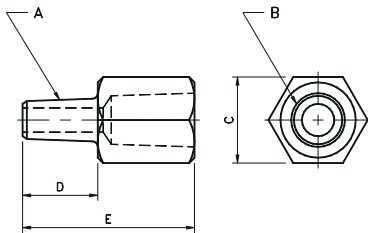

FEMALE TAPER TO MALE TAPER						
#130 Code No.	Male Taper	Female Taper	Stock Size	Length Under Head	Overall Length	Wrench Flats
	A	B	C	D	E	F
AT-R245-9	5 RW	4 RW	1	7/8	1-1/8	7/8
AT-R247-12	7 RW		1-1/8	1-1/4	1-1/2	1
AT-R257-12		5 RW				

#130 Code No.	Male Taper	Female Taper	Stock Size	Length Under Head	Overall Length
	A	B	C	D	E
AT-H254-15	4 RW	5 RW	1	7/8	1-7/8

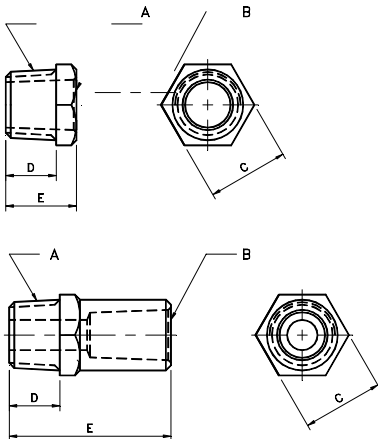

FEMALE TAPER TO MALE STRAIGHT THREAD					
#130 Code No.	Male Thread	Female Taper	Stock Size	Length Under Head	Overall Length
	A	B	C	D	E
AS-H245-7	5/8-18	4 RW	1	5/8	7/8
AS-H255-13		5 RW			1-5/8
AS-H247-7	7/8-14	4 RW	1-1/4		7/8
AS-H257-7		5 RW			
AS-H248-7	1-14	4 RW			
AS-H258-7		5 RW			

\* Sealing Ring included on Straight Threaded Adapters

### COPPER SEALING RINGS

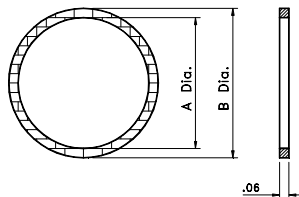

Part Number	A Dia.	B Dia.
760-0-0001	7/8 Dia.	1 Dia.
780-0-0001	1 Dia.	1-1/8 Dia.

EXAMPLE OF PART CODING:	
AS	= STRAIGHT THREAD
H	= HEX STOCK
R	= ROUND STOCK
2	= CLASS 2 COPPER
4	= #4 RW FEMALE TAPER
7	= EXTERNAL THREAD SIZE
8	= LENGTH IN 1/8" INCREMENTS