



Email: [Tipaloy@Tipaloy.com](mailto:Tipaloy@Tipaloy.com) Phone: 313-875-5145 Web: [www.Tipaloy.com](http://www.Tipaloy.com)

## SINGLE BEND TIPS

\*WATER COOLING REACHES THE NOSE OF THE TIP, INCREASING LIFE OVER TRADITIONAL CAST OR FORGED OFFSET TIPS.

\*WATER TUBES ARE SUPPLIED ON ALL DOUBLE BEND TIPS AND ON SEVERE SINGLE BEND TIPS. TIPS CAN BE SUPPLIED WITHOUT WATER TUBES ON REQUEST. THIS IS ONLY ADVISABLE IN VERY UNUSUAL APPLICATIONS.

**NOTE:** \*Quantity shipped on specials may run +/- 10% of order quantity. (2 pieces on runs under 25 pieces)  
\*Six piece minimum order on special bends.

### SINGLE BEND TIP CODING

|  |
|--|
| S=SINGLE BEND TIP  |
| 16=NOSE LENGTH IN 1/16" INCREMENTS   |
| P= POINTED NOSE=<br>DOME NOSE F= FLAT<br>NOSE O= OFFSET NOSE<br>R= RADIUS NOSE*  |
| 1 = ALLOY SPECIFICATION (RWMA CLASS 1) 2 =<br>ALLOY SPECIFICATION (RWMA CLASS 2) 3 = ALLOY<br>SPECIFICATION (RWMA CLASS 3)                                       |
| 4 = TAPER SPECIFICATION (#4 RW TAPER) 5 =<br>TAPER SPECIFICATION (#5 RW TAPER) 6 = TAPER<br>SPECIFICATION (#6 RW TAPER) 7 = TAPER<br>SPECIFICATION (#7 RW TAPER) |
| 2= LENGTH IN 1 INCH INCREMENTS   |
| 14= FRACTIONAL LENGTH IN 1/16" INCREMENTS  |
| 8= OFFSET IN 1/16" INCREMENTS  |
| EXAMPLE: S16-P14214-8  |
| *NOTE: Please specify radius   |

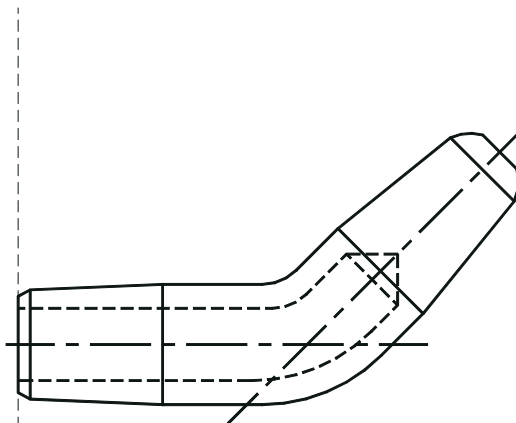
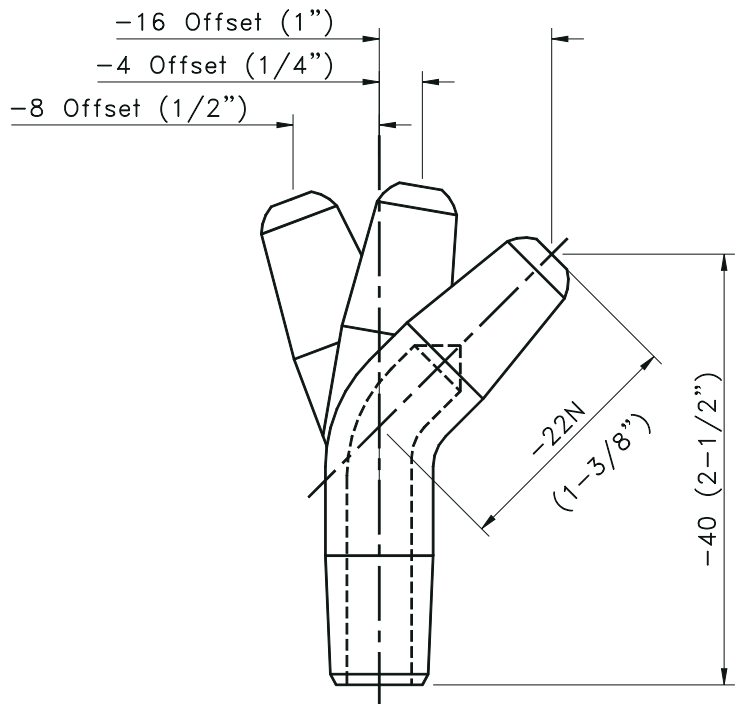

- 1/2"
- 1"
- 1-1/2"
- 2"
- 2-1/2"
- 3"
- 3-1/2"
- 4"
- 4-1/2"
- 5"
- 5-1/2"
- 6"