



UNITED STATES (313) 875-5145
 FAX (313) 875-6027
 WORLD WIDE WEB: WWW.TIPALOY.COM

CANADA (888) 847-2569
 FAX (888) 551-2055
 E-MAIL TIPALOY@TIPALOY.COM

WELD GUN CYLINDER HOLDERS

- *Designed for air and hydraulic guns and cylinders on resistance spot welding equipment.
- ***Individual supply of water and current** to each holder for better weld quality.
- ***Silver plated** barrel and clamp for higher conductivity and corrosion resistance.
- *Available for **4 RW, 5 RW, 6 RW, and 7 RW** taper electrodes.
- *When ordering, specify assembly size as shown below.
- ***To complete your set-up**, order hose barbs, adapters, stationary water tubes and sliding tubes to suit your specific requirements.
- ***Replacement parts may be ordered individually**

T-101

Barrel and Clamp Assembly
 For 4 RW and 5 RW Electrodes

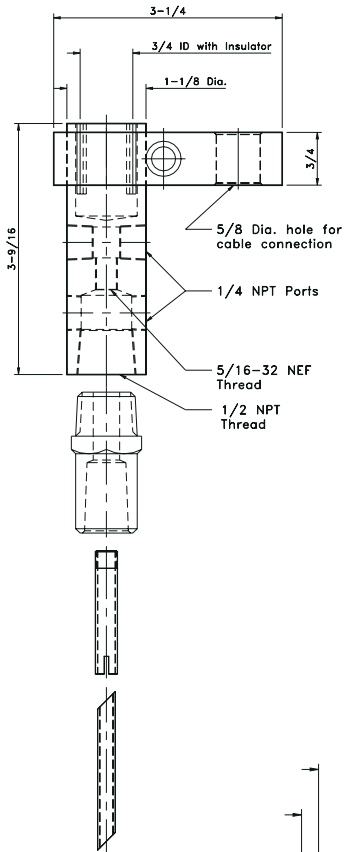

T-102

Barrel and Clamp Assembly
 For 6 RW or 7 RW Electrodes

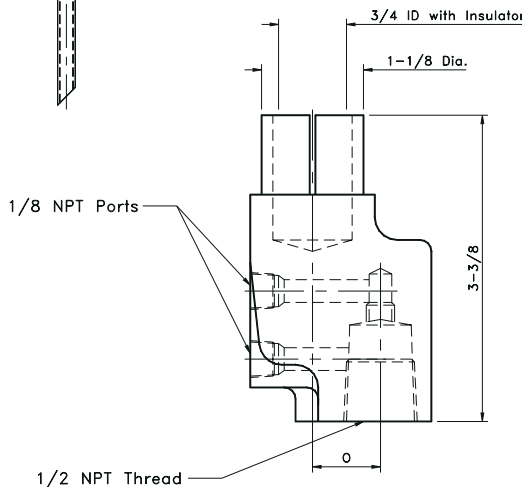
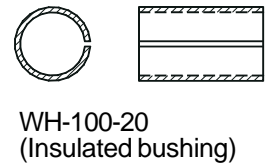
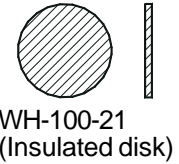
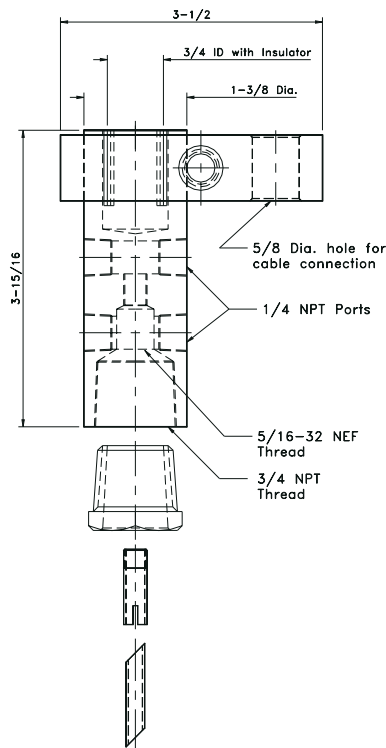

OFFSET HOLDERS

Part No.	Offset
	O
T-101-.50	1/2"
T-101-.75	3/4"
T-101-1.0	1"

OPTIONS

- * Additional offsets
- * #6 & #7 RW Tapers
- * 3/4 NPT water connections